

SINGER
9416/9430

LIST OF PARTS

Sewing Machine Series

9416

9430

by **SINGER** *



A Publication of Product Support
International Group Engineering

REV. DATE: 06/01 '89

Printed in Taiwan

From the library of: Diamond Needle Corp

INDEX

PAGE NO.	SUBASSEMBLY
1, 2	ATTACHMENT SET
3, 4	COVERS AND ADD ONS
5, 8	ARM TOP COVER
9, 10	ARM SHAFT DRIVE SYSTEM
11, 12	HAND WHEEL
13, 14	COAXIAL PRESSER BAR SYSTEM
15, 16	NEEDLE BAR & THREAD TAKE-UP
17, 22	ALPHA FEED
23, 24	HOOK SYSTEM (APOLLO)
25, 26	HOOK AND BOBBIN WINDING SYSTEM (CENTAUR)
27, 32	PATTERN, STITCH LENGTH CONTROL & CAM CONTROLLED FEED
33, 34	DEMAND RESPONSIVE NEEDLE TENSION SYSTEM
35, 38	ELECTRICAL EQUIPMENT

ATTACHMENT SET

REF. PART NO.	PART NO.	DESCRIPTION	9	9
			4	4
			1	3
			6	0
1	313030	ATTACHMENT COMPLETE		X
1	313031	ATTACHMENT COMPLETE		X
2	402673-455	ACCESSORY BOX COMPLETE (ALT:402673-454)	X	X
3	313117	FEED COVER PLATE	X	
5	172336	BOBBIN		X
6	312956	BOBBIN	X	
7	353364	NEEDLE PACK (ALT: 384064)	X	X
9	546358	LINT BRUSH	X	X
11	161172	SEAM & BLINDSTITCH HEM GUIDE COMPLETE	X	
13	313992-451	PRESSER FOOT PLATE (SNAP-ON) FOR SEWING BUTTONHOLES	X	X
15	171480	PRESSER FOOT PLATE (SNAP-ON) FOR CORDING & SLIDE FASTENERS COMPL.	X	X
17	171463	SPECIAL PURPOSE PRESSER FOOT PLATE (SNAP-ON)	X	X
18	384037	DARNING & EMBROIDERY FOOT COMPLETE (PLASTIC)	X	
20	421588	FINGER GUARD ATTACHED TO PRESSER BAR FOR ITALY AND U.S. SCHOOL MACHINES. IN ACCESSORY BOX FOR FRANCE	X	X
21	171110	BLINDSTITCH GUIDE	X	X

ATTACHMENT SET

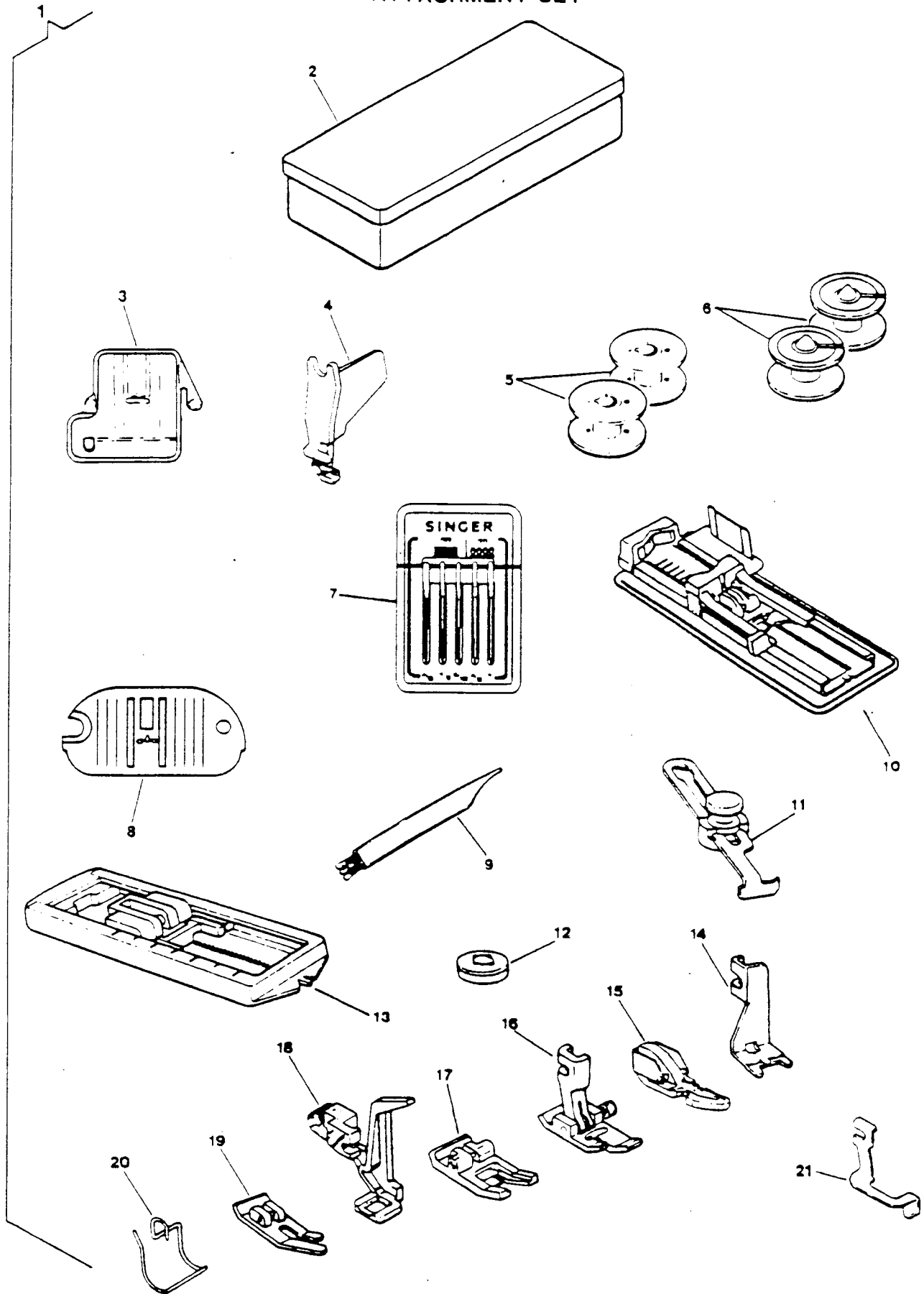

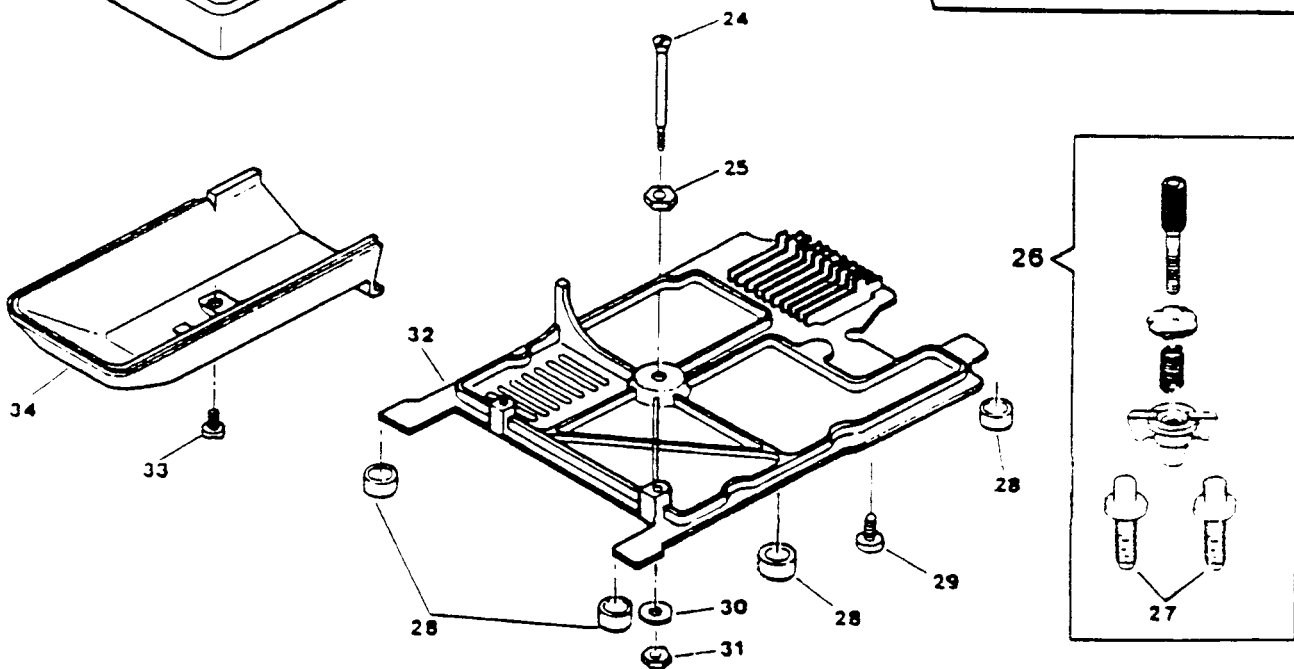
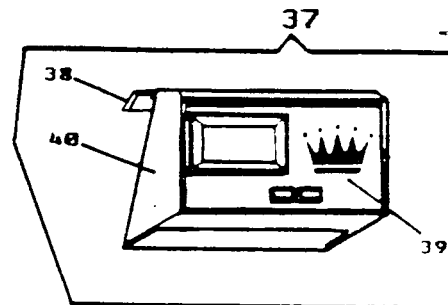
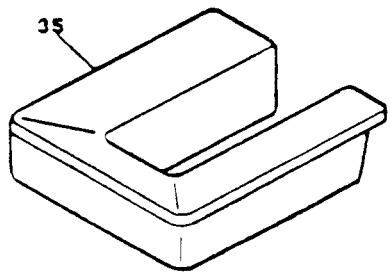
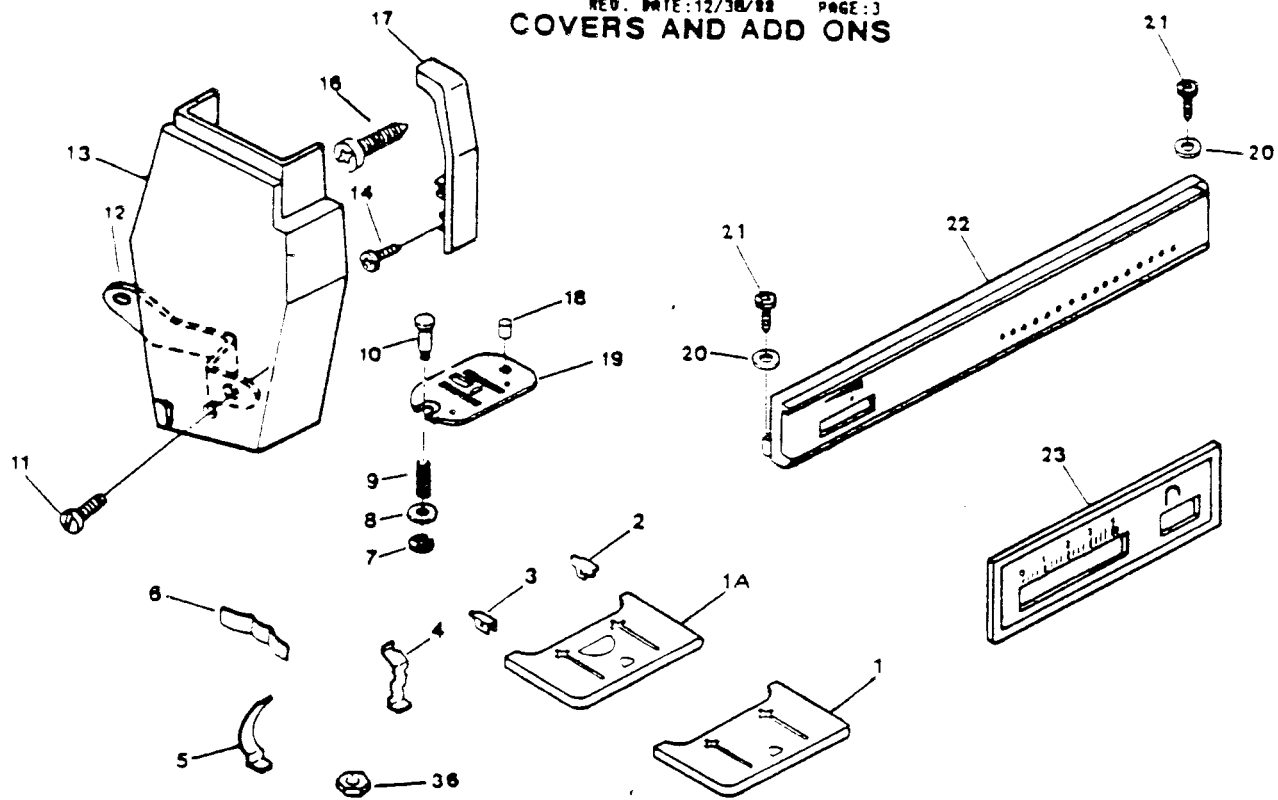

COVERS AND ADD ONS

REF. NO.	PART NO.	DESCRIPTION	9	9
			4	4
			1	3
			6	0
1	314666	BED-SLIDE ASSEMBLY COMPL. (APOLLO)	X	X
2	314669	BED SLIDE SPRING (RIGHT)	X	X
3	314670	BED SLIDE SPRING (LEFT)	X	X
4	313178	BED SLIDE STOP	X	X
5	313179	BED SLIDE STOP SPRING	X	X
6	313118	CLOTH PLATE SPRING	X	X
7	313098	THROAT PLATE PLUNGER RETAINING RING	X	X
8	549426-451	THROAT PLATE PLUNGER WASEHR	X	X
9	312805	THROAT PLATE PLUNGER SPRING	X	X
10	312804	THROAT PLATE PLUNGER	X	X
11	113521-451	FACE PLATE MOUNTING SCREW	X	X
12	314263	FACE PLATE MOUNTING BRACKET	X	X
13	314259-451	FACE PLATE COMPLETE	X	X
14	113470-003	THREAD TAKE-UP COVER MOUNTING SCREW	X	X
16	113455-004	THREAD TAKE-UP COVER MOUNTING SCREW	X	X
17	314718-451	THREAD TAKE-UP COVER	X	X
18	353624	THROAT PLATE LOCATING PIN	X	X
19	312777	THROAT PLATE FOR ZIG ZAG SEWING	X	X
22	314640-912	CONTROL PANEL WITH GRAPHICS	X	X
22	317025-910	CONTROL PANEL WITH GRAPHICS ASSEMBLY	X	
23	317116-001	STITCH LENGTH CONTROL PANEL ASSEMBLY	X	X
24	313052-451	BOTTOM COVER MOUNTING BOLT	X	X
25	313173-451	BOTTOM COVER MOUNTING BOLT MOUNTING NUT	X	X
26	313180	MACHINE HOLD DOWN MOUNTING KIT	X	X
27	148869	MACHINE LOCATOR PIN	X	X
28	313909-451	BED LEG CUSHION	X	X
29	113455-002	BED COVER PLATE (BOTTOM) SCREW	X	X
30	314712-451	BOTTOM COVER MOUNTING BOLT WASHER	X	X
31	313177-452	BOTTOM COVER MOUNTING BOLT MOUNTING NUT	X	X
32	312774-001	BED COVER PLATE (BOTTOM)	X	X
33	354633-452	BED COVER (TUBULAR) SCREW	X	X
34	312773-451	BED COVER TUBULAR	X	X
35	313882-451	CLOTH PLATE ASSEMBLY	X	X
36	313049	BED INSERT NUT	X	X

ARM TOP COVER

REF. NO.	PART NO.	DESCRIPTION	9	9
			4	4
			1	3
			6	0
1	314384-451	ARM TOP COVER MACHINE HANDLE		
2	314386	ARM TOP COVER MACHINE HANDLE HINGE BRACKET COMPLETE (2)	X	X
3	113520-451	ARM TOP COVER MACHINE HANDLE HINGE BRACKET SCREW (RIGHT & LEFT)	X	X
4	314485	ARM TOP COVER MACHINE HANDLE RETAINING SPRING	X	X
5	314561	ARM TOP COVER MACHINE HANDLE HINGE BRACKET NUT PLATE (LEFT)	X	X
6	314560	ARM TOP COVER MACHINE HANDLE HINGE BRACKET NUT PLATE (RIGHT)	X	X
7	317026-008	ARM TOP COVER ASSEMBLY	X	
7	317126-020	ARM TOP COVER ASSEMBLY	X	
8	314675	BOBBIN WINDER ASSEMBLY		X
9	314045-451	BOBBIN WINDER FRICTION RING	X	X
10	312897	BOBBIN WINDER LEVER SPRING	X	X
12	314672	BOBBIN WINDER LEVER HINGE STUD	X	X
14	314711-451	BOBBIN WINDER STOP SCREW NUT	X	X
15	312894	BOBBIN WINDER STOP	X	X
16	141808-453	BOBBIN WINDER STOP SCREW	X	X
17	313563	ARM TOP COVER THREAD GUIDE ASSEMBLY	X	X
18	354810-451	ARM TOP COVER THREAD GUIDE SCREW	X	X
19	313536	BOBBIN WINDER TENSION ASSEMBLY	X	X
20	179812	BOBBIN WINDER TENSION STUD	X	X
21	45847	BOBBIN WINDER TENSION DISC SPRING	X	X
22	45915	BOBBIN WINDER TENSION DISC	X	X
23	319606	BOBBIN WINDER TENSION STUD COLLAR	X	X
24	319663-452	BOBBIN WINDER TENSION STUD RETAINING RING	X	X
25	312940-451	SPOOL PIN (HORIZONTAL)	X	X
26	314337	ARM TOP COVER SUPPORT BRACKET	X	X
27	113442-002	ARM TOP COVER SUPPORT BRACKET SCREW (LEFT)	X	X
28	113516-451	ARM TOP COVER SUPPORT BRACKET SCREW (RIGHT)	X	X
29	179967-451	SPOOL PIN THREAD LEAD-OFF	X	X
30	354927-001	ARM TOP COVER MOUNTING SCREW (3)	X	X
31	312892	ARM TOP COVER MOUNTING PLATE (LEFT)	X	X
32	314275	ARM TOP COVER MOUNTING PLATE (RIGHT)	X	X

ARM TOP COVER

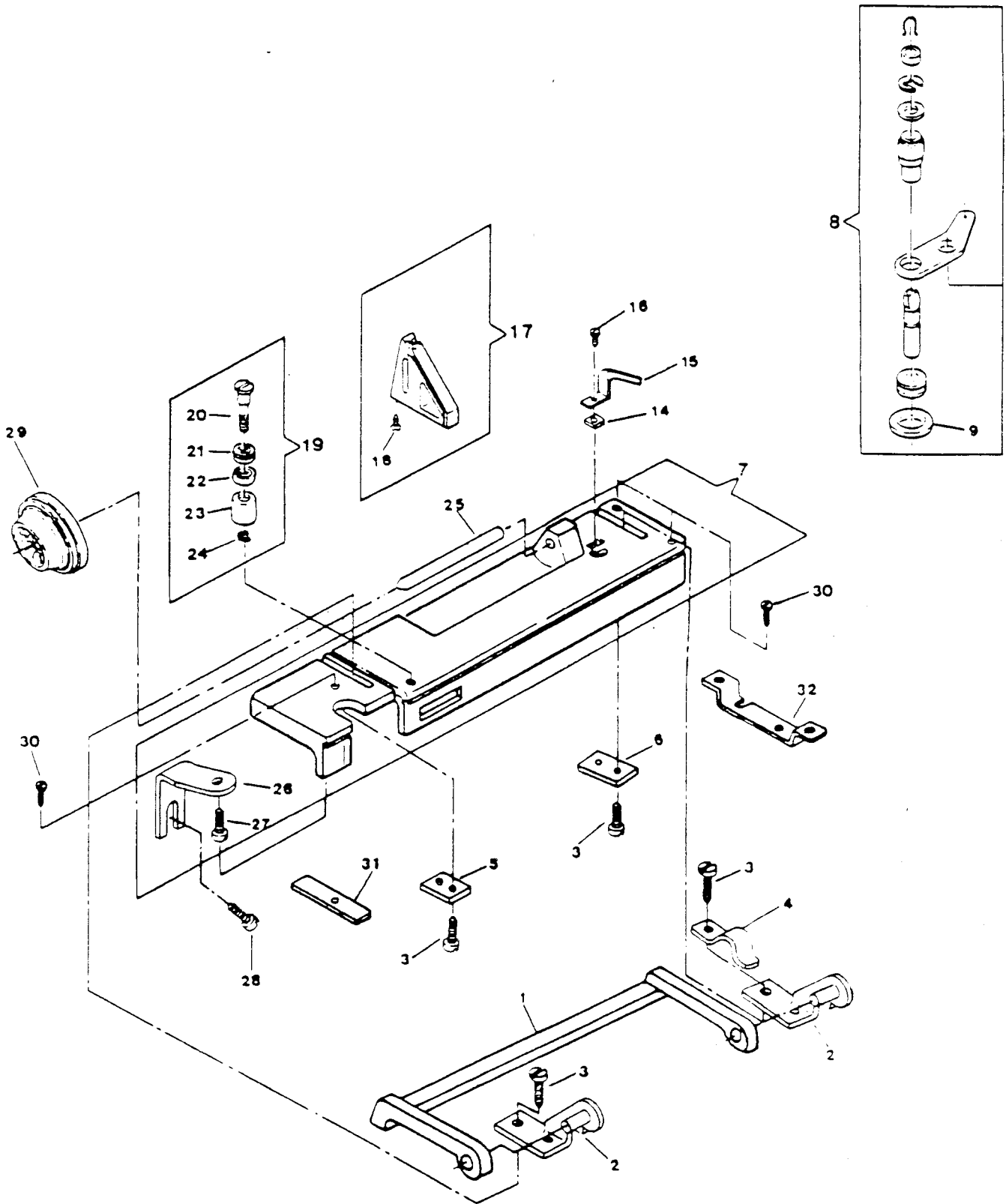

12

From the library of: Diamond Needle Corp

ARM SHAFT DRIVE SYSTEM

REF. PART NO. NO.	DESCRIPTION	9 4 1 5 0	
1	113455-001	ARM SHAFT (HORIZONTAL) BUSHING (LEFT & RIGHT) CLAMP SCREW	X X
2	312796	ARM SHAFT (HORIZONTAL) BUSHING (LEFT & RIGHT) CLAMP ASSEMBLY	X X
3	113488-451	THREAD TAKE-UP STUD SET SCREW	X X
6	313982	ARM SHAFT HORIZONTAL ASSEMBLY	X
6	313989	ARM SHAFT HORIZONTAL ASSEMBLY (ALTERNATE TO 313982)	X
6	313998	ARM SHAFT (HORIZONTAL) ASSEMBLY	X
6	313999	ARM SHAFT HORIZONTAL ASSEMBLY (ALTERNATE TO 313998)	X
7	312620-001	ARM SHAFT (HORIZONTAL) RETAINING COLLAR THRUST WASHER (PLASTIC)	X X
7A	312620-002	ARM SHAFT THRUST WASHER	X X
8	312795	ARM SHAFT (HORIZONTAL) BUSHING (LEFT & RIGHT)	X X
9	544208-001	ARM SHAFT (HORIZONTAL) RETAINING COLLAR SET SCREW	X X
10	312619	ARM SHAFT (HORIZONTAL) RETAINING COLLAR ASSEMBLY	X X
11	603975-011	BELT (ROTATING HOOK DRIVE) ALT:603975-012	X X
12	544212-003	ARM SHAFT (HORIZONTAL) BELT DRIVE PULLEY SCREW	X X
13	314074-901	ARM SHAFT (HORIZONTAL) BELT DRIVE PULLEY (PLASTIC)	X X
14	354591-451	DISC STACK DRIVING WORM GEAR SET SCREW	X X
15	312623	DISC STACK DRIVING WORM GEAR ASSEMBLY	X X
16	313153	HAND WHEEL RETAINING RING	X
17	314131	ROTATING HOOK DRIVE SHAFT BELT PULLEY ASSEMBLY	X X
18	544098	ROTATING HOOK DRIVE SHAFT BELT PULLEY SET SCREW	X X
19	113445-001	ROTATING HOOK DRIVE SHAFT BUSHING (SELF-ALIGNING) CLAMP SCREW	X X
20	314013-451	ROTATING H. D. SHAFT BUSHING (SELF-ALIGNING) CLAMP SCREW LOCK WASHER	X X
21	313816	ROTATING HOOK DRIVE SHAFT BUSHING (SELF-ALIGNING) CLAMP	X X
22	312700-001	ROTATING HOOK DRIVE SHAFT BUSHING (RIGHT) (SELF-ALIGNING)	X X
23	444900-452	ROTATING HOOK DRIVE SHAFT SPRING WASHER	X X
25	312685	ROTATING HOOK DRIVE SHAFT BEARING RETAINING RING	X X
26	313920	FEED DRIVE SHAFT DRIVING GEAR ASSEMBLY	X X
27	113466-451	FEED DRIVE SHAFT GEAR SET SCREW	X X
28	313936	ROTATING HOOK DRIVE SHAFT	X X
29	312700-002	ROTATING HOOK DRIVE SHAFT BUSHING (LEFT) (SELF-ALIGNING)	X X
31	544208-005	ROTATING HOOK DRIVE SHAFT BEVEL GEAR SET SCREW	X X
32	314011	ROTATING HOOK DRIVE SHAFT BEVEL GEAR ASSEMBLY ALT:314054-900	X X
33	313195	IDLER BRACKET ASSEMBLY	X X
34	313157	BELT IDLER PULLEY RETAINING RING	X X
35	382255	BELT IDLER PULLEY	X X
36	313001	IDLER BRACKET ASSEMBLY	X X
39	113455-002	ROTATING HOOK DRIVING BELT TENSION ADJUSTER SCREW	X X
40	314041-451	ROTATING HOOK DRIVING BELT TENSION ADJUSTER SCREW WASHER	X X
41	314013-451	ARM SHAFT BUSHING (LAMP SCREW WASHER)	X X

ARM SHAFT DRIVE SYSTEM

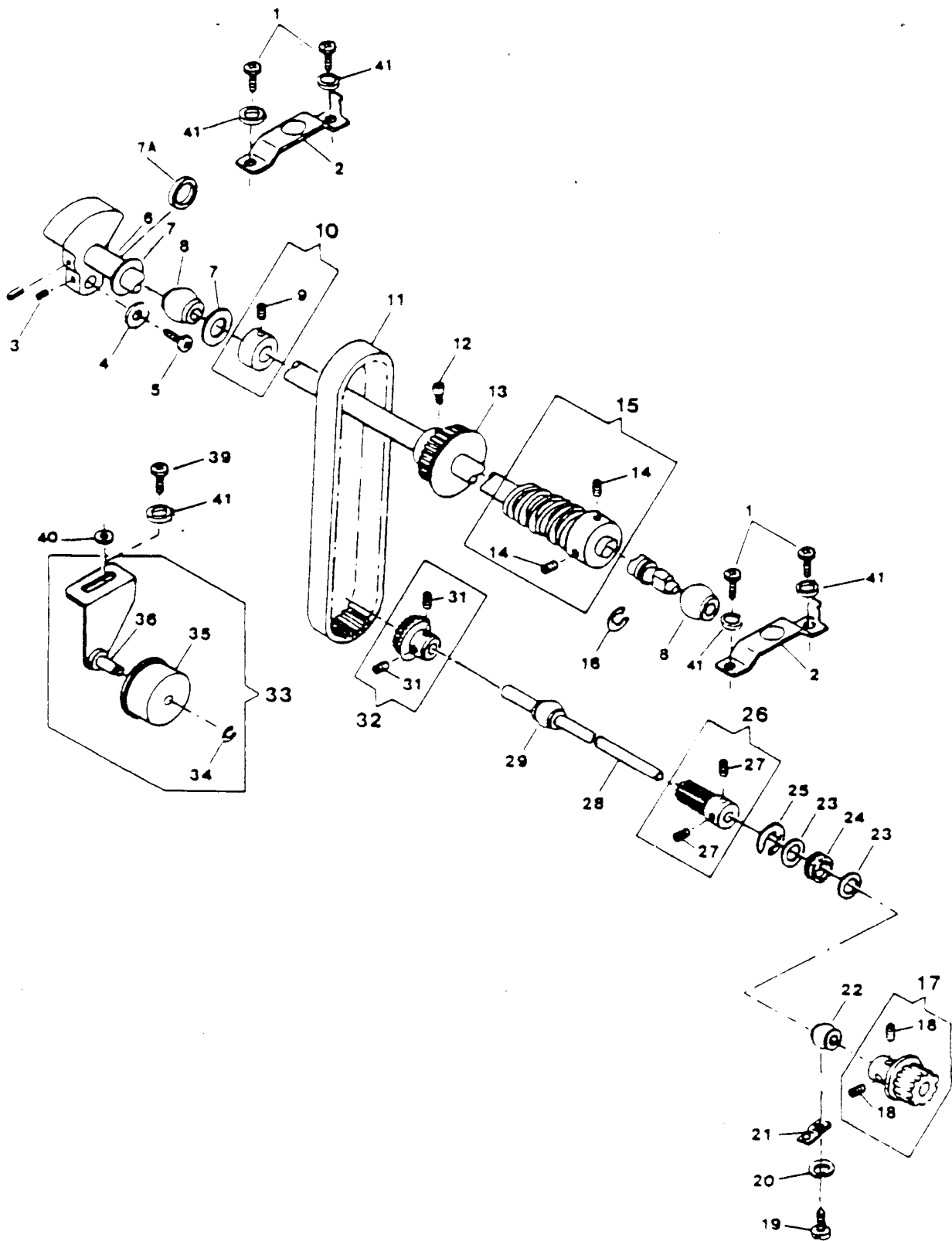

HAND WHEEL

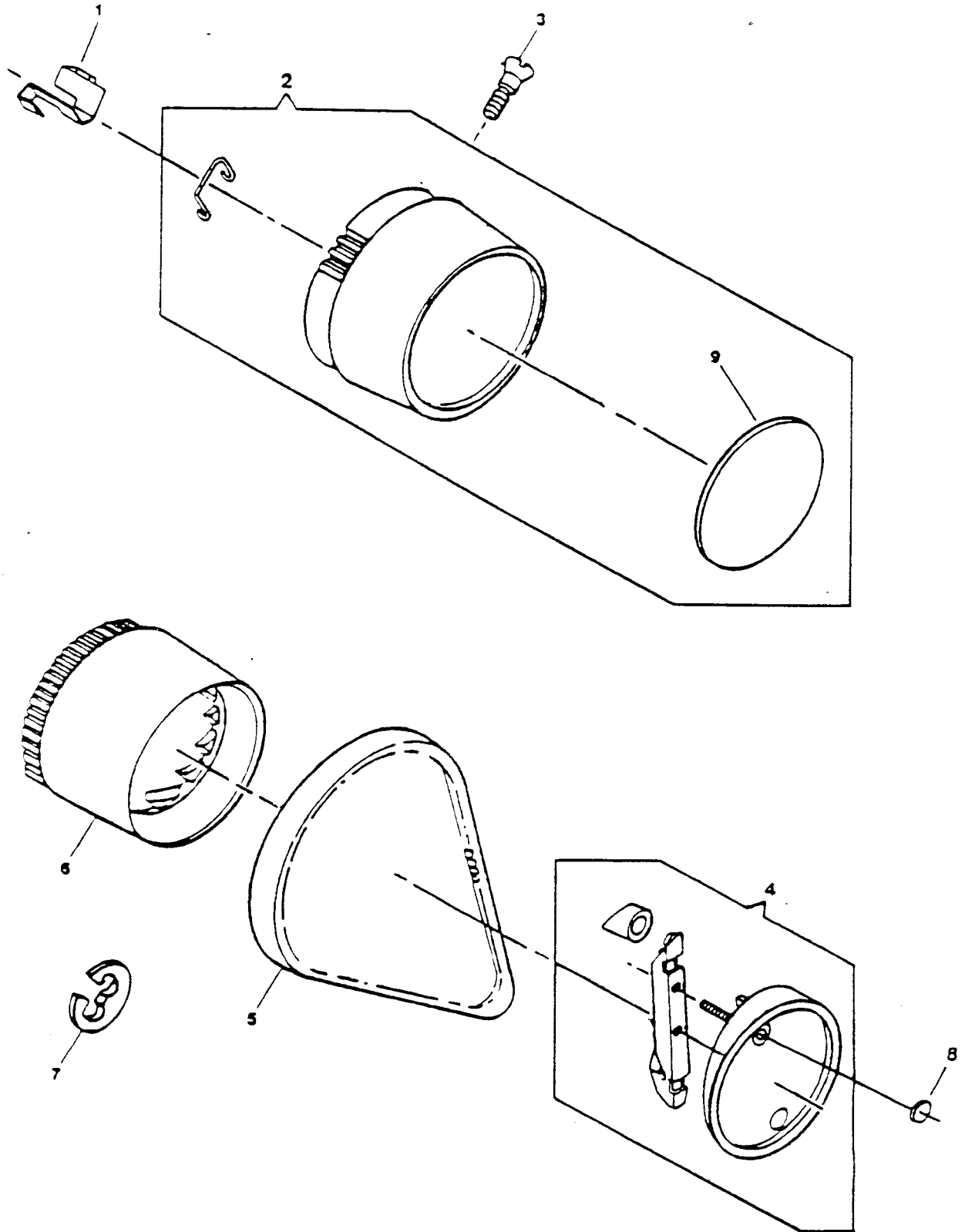

HAND WHEEL

REF. PART NO. NO.	DESCRIPTION	9 9 4 4 1 3 5 0
4 313185-451	HAND WHEEL CLUTCH PLATE ASSEMBLY	
5 312628-001	BELT (MOTOR DRIVE) ALT: 979285-001	X X
6 312625-451	HAND WHEEL (PLASTIC)	X X
7 313153	HAND WHEEL RETAINING RING	X X
8 314733-900	HAND WHEEL ACCESS PLATE (APOLLO)	X X X X

COAXIAL PRESSER BAR SYSTEM FOR NEW HEAD END

REF. PART NO. NO.	DESCRIPTION	9 9 4 4 1 3 6 0
1	314696 HEAD END MOUNTING PLATE ASSEMBLY COMP.	X X
2	314582 PRESSER BAR LIFTER	X X
3	314580 NEEDLE BAR & PRESSER BAR ADJUSTING BRACKET (SUB-ASSEMBLY)	X X
4	544208-001 NEEDLE BAR VIBRATING BRACKET BALL BUSHING (UPPER) ADJUSTER SET SCREW	X X
5	113485-452 NEEDLE BAR PRESSER BAR ADJUSTING BRACKET MOUNTING SCREW	X X
6	314583-901 PRESSER BAR GUIDE BRACKET	X X
7	141936-833 PRESSER BAR GUIDE BRACKET SCREW	X X
8	314584 PRESSER BAR SPRING RETAINING RING (UPPER)	X X
9	353214 PRESSER BAR SPRING	X X
10	314585 PRESSER BAR SPRING RETAINING RING (LOWER)	X X
11	314591 FACE PLATE MOUNTING BRACKET	X X
12	313955-451 HEAD END MOUNTING PLATE LOCK WASHER	X X
13	113455-012 HEAD END MOUNTING PLATE SCREW	X X
14	314581 PRESSER BAR	X X
15	163706-451 PRESSER FOOT SHANK (SNAP-ON)	X X
16	313150 PRESSER FOOT PLATE (SNAP-ON) FOR ZIG-ZAG SEWING	X X
17	113531-451 PRESSER FOOT THUMB SCREW	X X
19	113455-001 NEEDLE THREAD TENSION RELEASE LEVER HINGE SCREW	X X
20	314041-451 NEEDLE THREAD TENSION RELEASE LEVER RETAINING WASHER	X X
21	314589 NEEDLE THREAD TENSION RELEASE LEVER ASSEMBLY	X X

COAXIAL PRESSER BAR SYSTEM

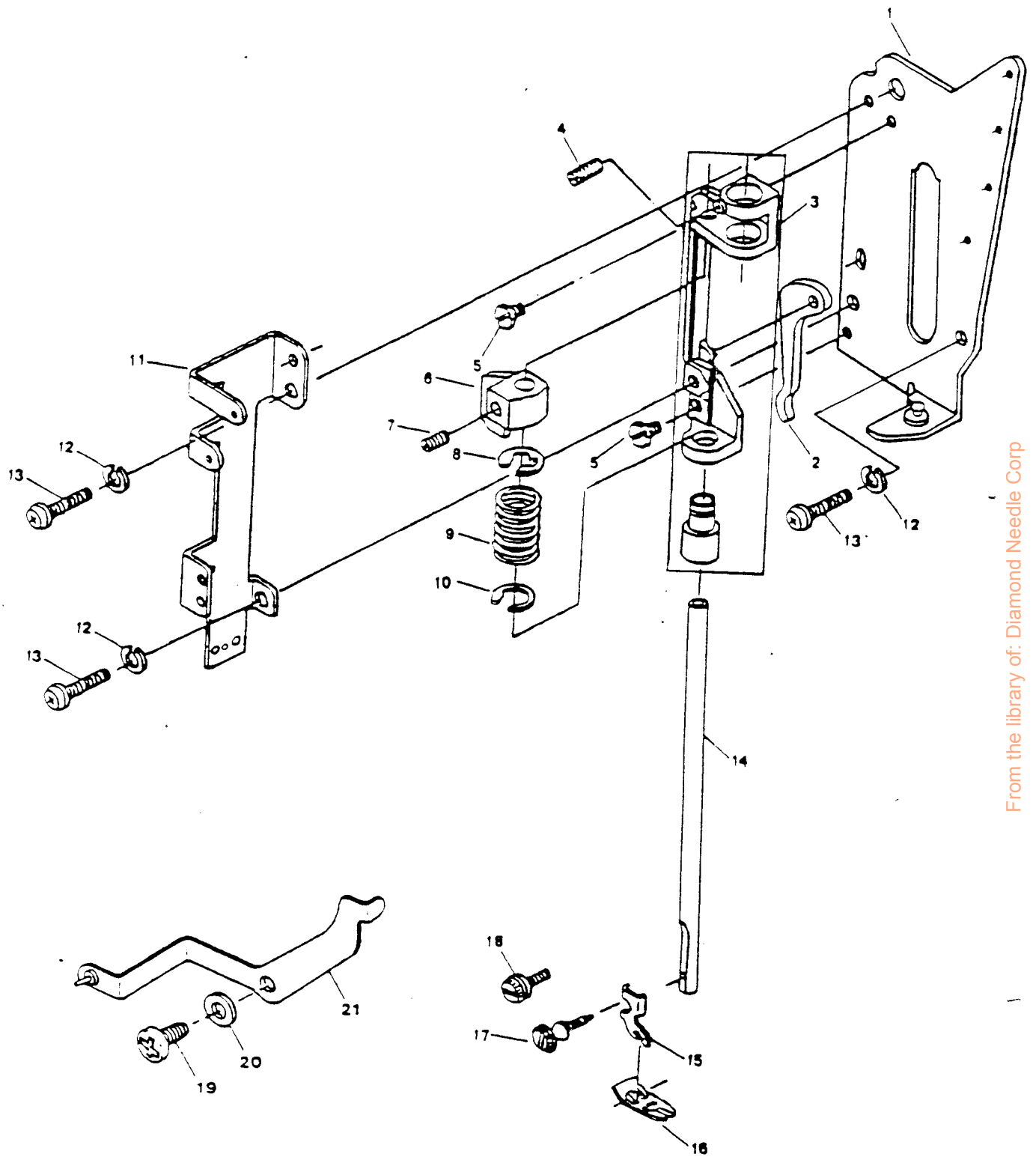

NEEDLE BAR AND THREAD TAKE-UP

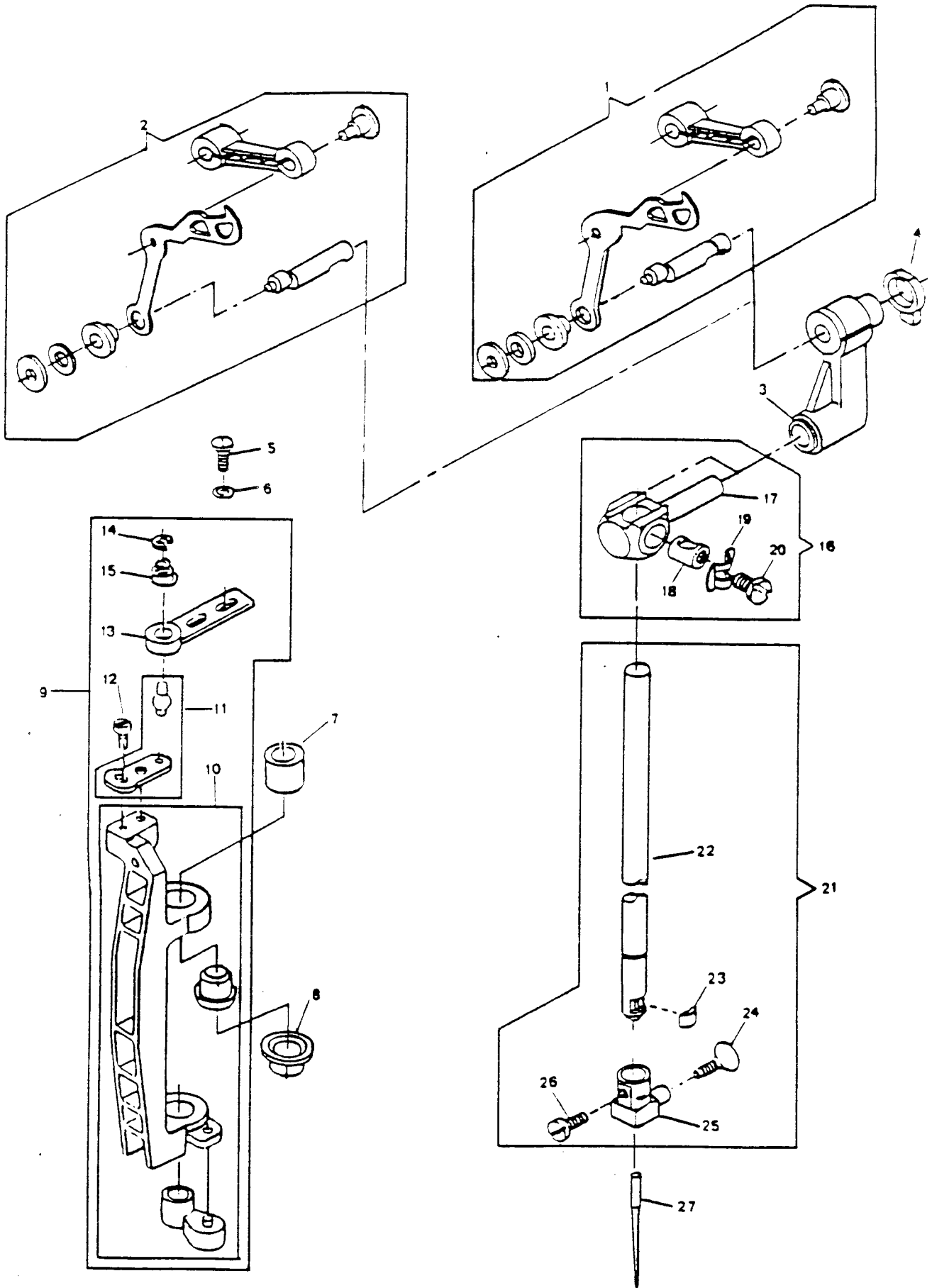

NEEDLE BAR & THREAD TAKE-UP FOR NEW HEAD.END

REF. PART NO. NO.	DESCRIPTION	9 9 4 4 1 3 6 0	
1	314694	THREAD TAKE-UP COMPLETE (APOLLO)	
3	313533	NEEDLE BAR CONNECTING LINK ASSEMBLY	X X
4	314146	NEEDLE BAR CONNECTING LINK SPACER	X X
5	113408-001	NEEDLE BAR DRIVING ARM BALL JOINT SCREW	X X
6	931929-004	NEEDLE BAR DRIVING ARM BALL JOINT SCREW WASHER	X X
7	314574	NEEDLE BAR VIBRATING BRACKET BUSHING (UPPER)	X X
8	314573	NEEDLE BAR BALL BUSHING SOCKET (LOWER)	X X
9	314569	NEEDLE BAR VIBRATING BRACKET ASSEMBLY	X X
10	314614	NEEDLE BAR VIBRATING BRACKET SUB-ASSEMBLY	X X
11	314570	NEEDLE BAR VIBRATING BRACKET STUD PLATE ASSEMBLY	X X
12	141920-451	NEEDLE BAR VIBRATING BRACKET STUD PLATE ASSEMBLY MOUNTING SCREW	X X
13	312839	NEEDLE BAR DRIVING ARM BALL JOINT	X X
14	312702	NEEDLE BAR DRIVING ARM BALL JOINT RETAINING RING	X X
15	382602	NEEDLE BAR DRIVING ARM BALL JOINT SPRING	X X
16	313191	NEEDLE BAR CONNECTING STUD SUB-ASSEMBLY	X X
17	312751	NEEDLE BAR CONNECTING STUD	X X
18	312769	NEEDLE BAR CONNECTING STUD HINGE PIN	X X
19	384000	NEEDLE BAR CONNECTING STUD HINGE PIN FRICTION WASHER	X X
20	354972-451	NEEDLE BAR CLAMPING & GUIDE SCREW	X X
21	313192	NEEDLE BAR SUB-ASSEMBLY	X X
22	313553	NEEDLE BAR	X X
23	313552	NEEDLE BAR GIB	X X
24	354898-451	NEEDLE THUMB SCREW	X X
25	313798	NEEDLE CLAMP BODY	X X
26	141920-454	NEEDLE CLAMP BODY NEEDLE CLAMP THREAD GUIDE & NEEDLE STOP SCREW	X X
27	N2045	NEEDLE SIZE NO. 14 (IN MACHINE)	X X

ALPHA FEED

REF. NO.	PART NO.	DESCRIPTION	9	9
			4	4
			1	3
			6	0
1	141920-452	FEED DOG SCREW	X	X
2	312679	FEED DOG (APOLLO)	X	X
2	313171	FEED DOG (APOLLO) (ALTERNATE PYRAMID)	X	X
3	314140-002	ALPHA FEED MODULE	X	X
4	511213	FEED DOG HOLDER STUD RETAINING RING	X	X
5	511052	FEED DOG HOLDER STUD	X	X
6	422334-902	FEED DOG HOLDER (MACHINED)	X	X
7	544100	FEED DOG HOLDER STUD SCREW	X	X
8	511210	FEED DOG HOLDER WASHER	X	X
9	354983-451	FEED BAR CONNECT'G & FEED LIFT'G FORK CONNECT'G HINGE STUD (ECCENTRIC) SET SCREW (ALT: 354420-451)	X	X
10	422561	FEED DOG HOLDER COMPENSATING LINK RETAINING SPRING (FRONT)	X	X
11	422337	FEED DOG HOLDER COMPENSATING LINK RETAINING SPRING (BACK)	X	X
12	422335-001	FEED DOG HOLDER COMPENSATING LINK	X	X
13	514744-451	FEED BAR PIVOT HINGE STUD LOCK SCREW	X	X
14	314142	FEED BAR PIVOT HINGE STUD PIN	X	X
15	422338	FEED BAR HINGE PIN WASHER	X	X
16	422333-902	FEED BAR	X	X
17	511211	FEED BAR GUIDE HINGE PIN SPRING WASHER	X	X
18	422340-001	FEED BAR PIVOT HINGE STUD	X	X
19	314141	FEED BAR ASSEMBLY	X	X
20	312851	FEED BAR PIVOT HINGE STUD CLAMP	X	X
21	113455-003	FEED BAR PIVOT HINGE STUD CLAMP SCREW	X	X

ALPHA FEED

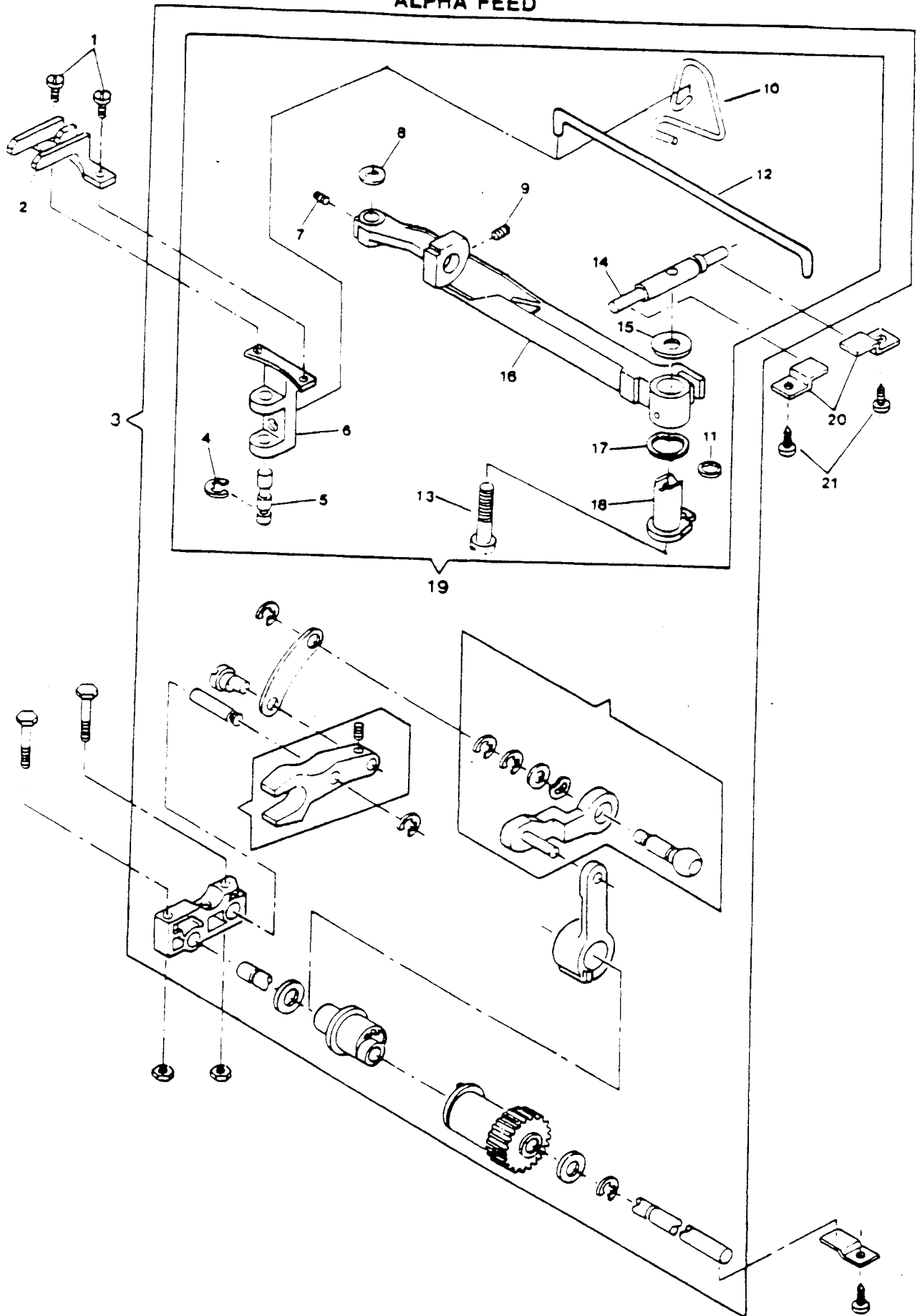

ALPHA FEED (CONT.)

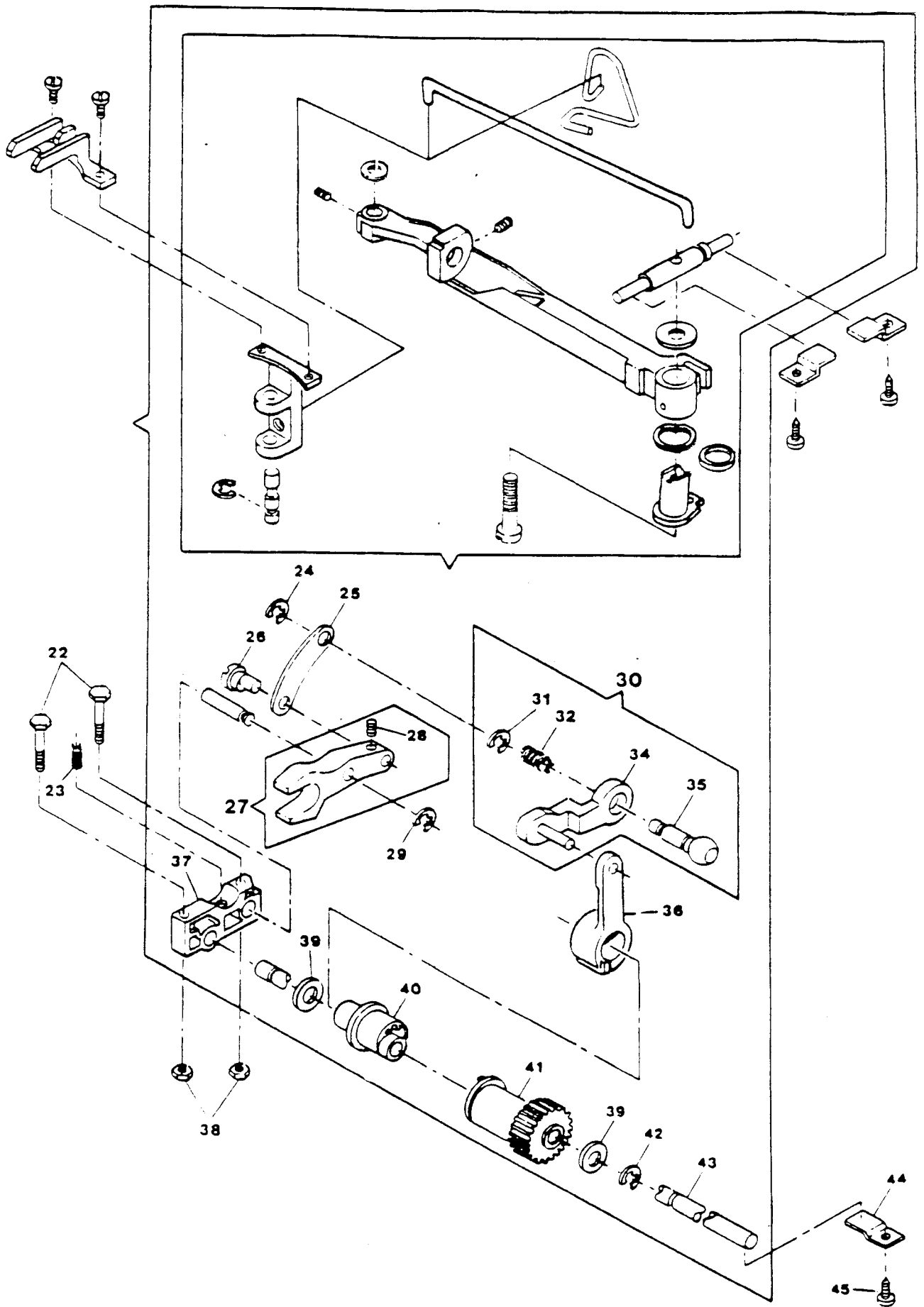

ALPHA FEED (CONT.)

REF. NO.	PART NO.	DESCRIPTION	9	4	1	3	6	0
22	354921-451	FEED & ROTATING HOOK DRIVE SHAFT BEARING BLOCK MOUNTING SCREW	X	X				
23	314070	ROTATING HOOK DRIVE SHAFT BUSHING SPRING	X	X				
24	312686	FEED LIFTING FORK CONNECTING RETAINING RING	X	X				
25	511016	FEED LIFTING FORK CONNECTION	X	X				
26	511056	FEED LIFTING FORK CONNECTING HINGE STUD (ECCENTRIC)	X	X				
27	503325-002	FEED LIFTING FORK COMPL.	X	X				
28	514685-451	FEED LIFTING FORK CONNECTING HINGE STUD (ECCENTRIC) SET SCREW	X	X				
29	312685	FEED & ROTATING HOOK DRIVE SHAFT BEARING BLOCK STUD RETAINING RING	X	X				
30	313910	FEED BAR CONNECTION ASSEMBLY COMPLETE	X	X				
31	312685	FEED BAR CONNECTION AND FEED LIFTING FORK CONNECTION HINGE STUD (ECCENTRIC) RETAINING RING	X	X				
32	314030	FEED BAR CONNECTION SPRING	X	X				
34	313130	FEED BAR CONNECTION ASSEMBLY	X	X				
35	313456	FEED BAR CONNECTION AND FEED LIFTING FORK CONNECTION HINGE STUD (ECCENTRIC) ALT: 312852	X	X				
36	312872-900	FEED REGULATOR SLIDE BLOCK DRIVE CONNECTION	X	X				
37	312864	FEED & ROTATING HOOK DRIVE SHAFT BEARING BLOCK ASSEMBLY	X	X				
38	514674-451	FEED & ROTATING HOOK DRIVE SHAFT BEARING BLOCK MOUNTING SCREW NUT	X	X				
39	312879-451	FEED DRIVE SHAFT GEAR WASHER	X	X				
40	312869	FEED LIFTING CAM & FEED ECCENTRIC (APOLLO)	X	X				
41	312902	FEED DRIVE SHAFT GEAR (PLASTIC)	X	X				
42	312686	FEED DRIVE SHAFT GEAR RETAINING RING	X	X				
43	312862-900	FEED DRIVE SHAFT	X	X				
44	312851	FEED DRIVE SHAFT CLAMP	X	X				
45	113455-003	FEED DRIVE SHAFT CLAMP SCREW	X	X				

ALPHA FEED (CONT.)

REF. PART NO.	PART NO.	DESCRIPTION	9	9
			4	4
			1	3
			6	0
1	313133	FEED REGULATOR SHAFT ASSEMBLY	X	X
2	511030	FEED REGULATOR SLIDE BLOCK	X	X
3	312874	FEED REGULATOR COMPL.	X	X
4	113515-451	FEED REGULATOR SCREW	X	X
5	314173	FEED REGULATOR SHAFT	X	X
6	312700-002	FEED REGULATOR SHAFT BUSHING (SELF-ALIGNING)	X	X
7	314175	FEED REGULATOR SHAFT TENSION SPRING ADJUSTING COLLAR ASSEMBLY	X	X
8	544207-001	FEED REGULATOR SHAFT TENSION SPRING ADJUSTING COLLAR SCREW	X	X
9	314172	FEED REGULATOR SHAFT TENSION SPRING	X	X
10	312875	FEED REGULATOR SHAFT RETAINING RING	X	X
11	312801	STITCH LENGTH CONTROL CRANK	X	X
12	354922-451	STITCH LENGTH CONTROL CRANK SCREW	X	X
13	313816	FEED REGULATOR SHAFT BUSHING (SELF-ALIGNING) CLAMP	X	X
14	314013-451	FEED REGULATOR SHAFT BUSHING (SELF-ALIGNING) CLAMP SCREW LOCK WASHER	X	X
15	113455-001	FEED REGULATOR SHAFT BUSHING (SELF-ALIGNING) CLAMP SCREW	X	X

ALPHA FEED (CONT.)

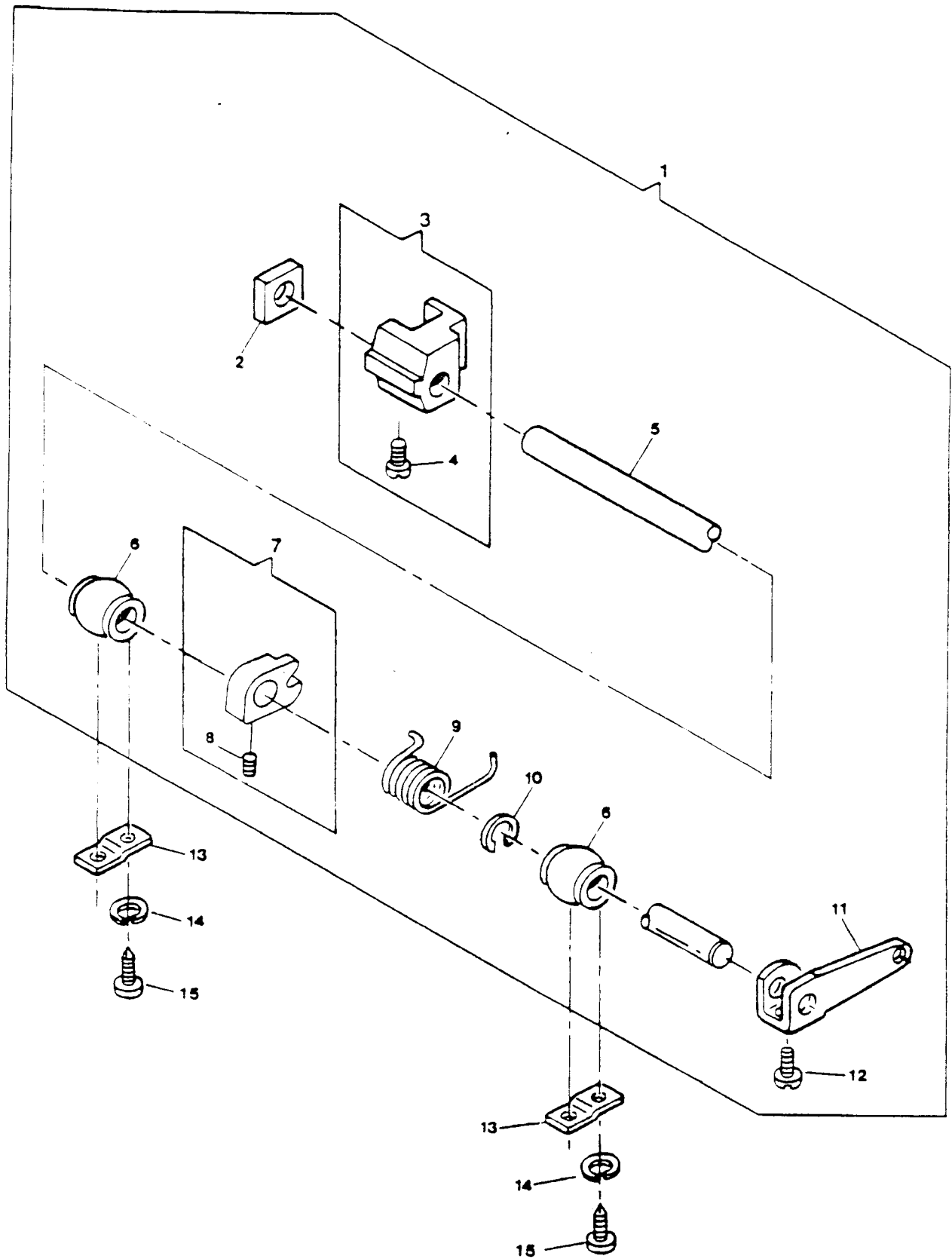

HOOK SYSTEM (APOLLO)

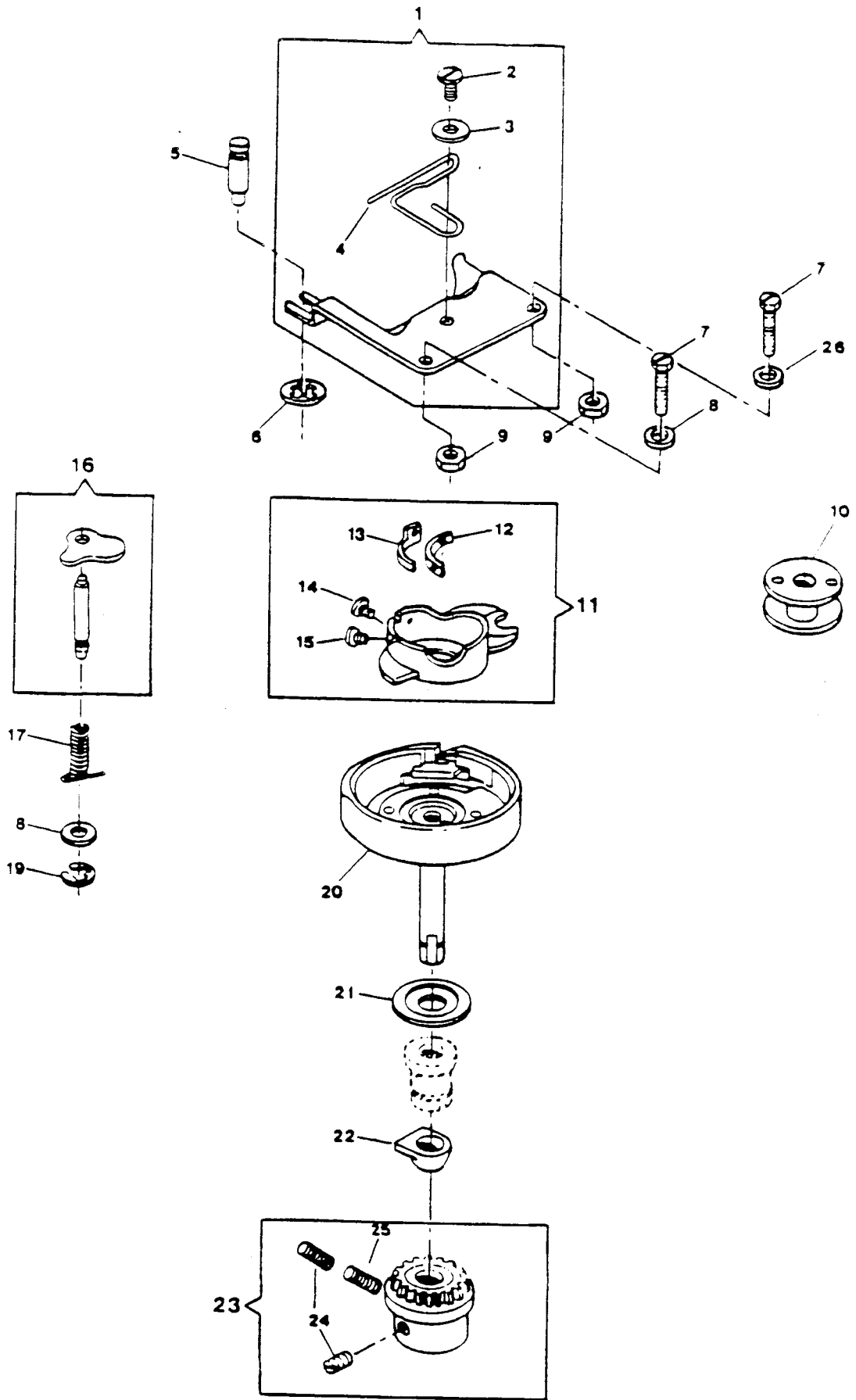

HOOK SYSTEM (APOLLO)

REF. NO.	PART NO.	DESCRIPTION	9	9
1	313089	ROTATING HOOK BOBBIN CASE POSITION PLATE ASSEMBLY	X	X
1	314066	ROTATING HOOK BOBBIN CASE POSITION PLATE ASSEMBLY (ALTERNATE TO 313089)	X	X
2	354883-451	ROTATING HOOK BOBBIN CASE CUSHION SPRING SCREW	X	X
3	313190-451	ROTATING HOOK BOBBIN CASE CUSHION SPRING SCREW WASHER	X	X
4	313067-900	ROTATING HOOK BOBBIN CASE CUSHION SPRING	X	X
5	312603	ROTATING HOOK BOBBIN CASE POSITION PLATE HOLD DOWN STUD	X	X
6	313161	ROTATING HOOK BOBBIN CASE POSITION PLATE HOLD DOWN STUD RETAINING RING	X	X
7	113439-451	ROTATING HOOK BOBBIN CASE POSITION PLATE SCREW	X	X
8	313190-451	ROTATING HOOK BOBBIN CASE POSITION PLATE SCREW WASHER (LEFT)	X	X
9	313945-451	ROTATING HOOK BOBBIN CASE POSITION PLATE SCREW NUT	X	X
10	172336	ROTATING HOOK BOBBIN (PLASTIC)	X	X
11	421325	ROTATING HOOK BOBBIN CASE COMPLETE	X	X
12	310884-452	ROTATING HOOK BOBBIN CASE TENSION SPRING SEGMENT	X	X
13	310883	ROTATING HOOK BOBBIN CASE TENSION SPRING	X	X
14	139975-452	ROTATING HOOK BOBBIN CASE TENSION SPRING SEGMENT SCREW	X	X
15	354183-452	ROTATING HOOK BOBBIN CASE TENSION REGULATING SCREW	X	X
16	312846	ROTATING HOOK BOBBIN CASE RETAINING PLATE SUB ASSEMBLY	X	X
17	312607	ROTATING HOOK BOBBIN CASE RETAINING PLATE STUD SPRING	X	X
18	313190-451	ROTATING HOOK BOBBIN CASE RETAINING PLATE STUD WASHER	X	X
19	313783	ROTATING HOOK BOBBIN CASE RETAINING PLATE STUD RETAINING RING	X	X
20	314025	ROTATING HOOK COMPLETE (ALTERNATE TO 313034)	X	X
21	314049	ROTATING HOOK FLANGED BUSHING THRUST WASHER	X	X
22	312847	ROTATING HOOK FLANGED BUSHING WASHER	X	X
23	314012	ROTATING HOOK BEVEL GEAR COMPLETE	X	X
24	544207-012	ROTATING HOOK BEVEL GEAR (PLASTIC) SET SCREW	X	X
25	544207-011	ROTATING HOOK BEVEL GEAR SET SCREW	X	X
26	446138	ROTATING HOOK BOBBIN CASE POSITION PLATE SCREW WASHER (RIGHT)	X	X

PATTERN, STITCH LENGTH CONTROL & CAM CONTROLLED FEED (CONT.)

REF. NO.	PART NO.	DESCRIPTION	9	9
1	312685	BUTTONHOLER KICK-OUT SHAFT TRIPPING LEVER RETAINING RING	X	
2	313392	BUTTONHOLER LEVER PIVOT	X	
3	354877-451	BUTTONHOLE PIVOT LEVER SCREW	X	
4	312994-003	BUTTONHOLE KICK-OUT TRIPPING ROD LEVER ASSEMBLY	X	
5	312982	BUTTONHOLE TRIPPING LEVER ROD	X	
6	313005	BUTTONHOLE DISC CONTROL CATCH RELEASE LINK	X	
7	314763-451	BUTTONHOLE TRIPPING ROD ADJUSTING & LOCKING NUT	X	
8	354935-451	BUTTONHOLE ACTUATOR CAM ADJUSTING BRACKET SCREW	X	
9	313073	BUTTONHOLE ACTUATOR CAM ADJUSTING BRACKET	X	
10	313022	BUTTONHOLE FOLLOWER HUB RELEASE	X	
11	313023	BUTTONHOLE FOLLOWER HUB RELEASE PIN	X	
12	313025	BUTTONHOLE ACTUATOR CAM	X	
13	314497	NEEDEL BAR DRIVING ARM SLIDE POSITIONING SPRING	X	X
14	113455-001	DISC SELECTOR MECHANISM MOUNTING PLATE SCREW (LEFT & RIGHT)	X	X
15	314013-451	DISC SELECTOR MECHANISM MOUNTING PLATE SCREW (LEFT & RIGHT) LOCK WASHER	X	X
16	314676-460	BIGHT AMPLITUDE CONTROL LEVER KNOB (PLASTIC)	X	X
17	314601-001	PATTERN SELECTOR MODULE	X	
17	314613-002	PATTERN SELECTOR MODULE	X	
18	314492	NEEDLE BAR DRIVING ARM ASS'Y	X	X
19	313053	NEEDLE BAR DRIVING ARM RETURN SPRING	X	X
20	354984-451	FEED FOLLOWER BUTTONHOLE ADJUSTING ACTUATOR SCREW	X	
21	314527	FEED FOLLOWER ACTUATOR SPACER	X	X
22	314526	FEED FOLLOWER BUTTONHOLE ADJUSTING ACTUATOR	X	X
23	317044	PATTERN SELECTOR INDICATOR ASSEMBLY	X	X
24	312916	PATTERN SELECTOR CORD ASSEMBLY	X	X
25	313888	PATTERN SELECTOR CORD	X	X
26	312917	PATTERN SELECTOR CORD TENSION SPRING	X	X
27	313113	PATTERN SELECTOR INDICATOR DETENT SPRING	X	X
28	354899-451	PATTERN SELECTOR INDICATOR DETENT SPRING SCREW	X	X
29	313033	BUTTONHOLE DISC CONTROL CATCH SPRING	X	
30	314153	PATTERN SELECTOR KNOB SPACER	X	X
31	314239-461	PATTERN SELECTOR KNOB AND STITCH BALANCE KNOB	X	X
32	313535	PATTERN SELECTOR KNOB COMPRESSION RING	X	X
33	314744-455	PATTERN SELECTOR KNOB TRIM PLATE	X	
33	314744-466	PATTERN SELECTOR KNOB TRIM PLATE	X	
34	502495-451	FEED FOLLOWER BUTTONHOLE ADJUSTING ACTUATOR SCREW WASHER	X	X
35	314493	STITCH WIDTH CONTROL BRACKET WASHER (FRONT)	X	X
36	314494	STITCH WIDTH CONTROL BRACKET WASHER (BACK)	X	X
37	314557	PATTERN SELECTOR INDICATOR REINFORCING DETENT SPRING	X	X
38	314553	PATTERN SELECTOR DRUM STABILIZING SPRING	X	X
39	113487-451	PATTERN SELECTOR DRUM STABILIZING SPRING SCREW	X	X
40	314502	BIGHT AMPLITUDE CONTROL BRACKET RETAINING RING	X	X
41	314603	BIGHT AMPLITUDE CONTROL BRACKET ASSEMBLY	X	X
42	314606	BIGHT AMPLITUDE CONTROL ROD RETAINING (LEFT)	X	X
43	312879-451	BIGHT AMPLITUDE CONTROL LEVER FRICTION WASHER	X	X
44	354875-451	BIGHT AMPLITUDE CONTROL BRACKET PIVOT SCREW	X	X
45	314607	BIGHT AMPLITUDE CONTROL LEVER ASSEMBLY	X	
46	314610	BIGHT AMPLITUDE CONTROL LEVER STOP	X	
47	113455-014	BIGHT AMPLITUDE CONTROL LEVER STOP ADJUSTMENT SCREW	X	
48	314611	BIGHT AMPLITUDE CONTROL LEVER SHOULDER WASHER	X	
49	353457	BIGHT AMPLITUDE CONTROL LEVER FRICTION WASHER	X	
50	314683	BIGHT AMPLITUDE CONTROL LEVER RETAINER	X	
51	313799	BUTTONHOLE ACTUATOR ADJUSTING ROD SPRING	X	

PATTERN STITCH LENGTH CONTROL AND CAM CONTROLLED FEED (CONT.)

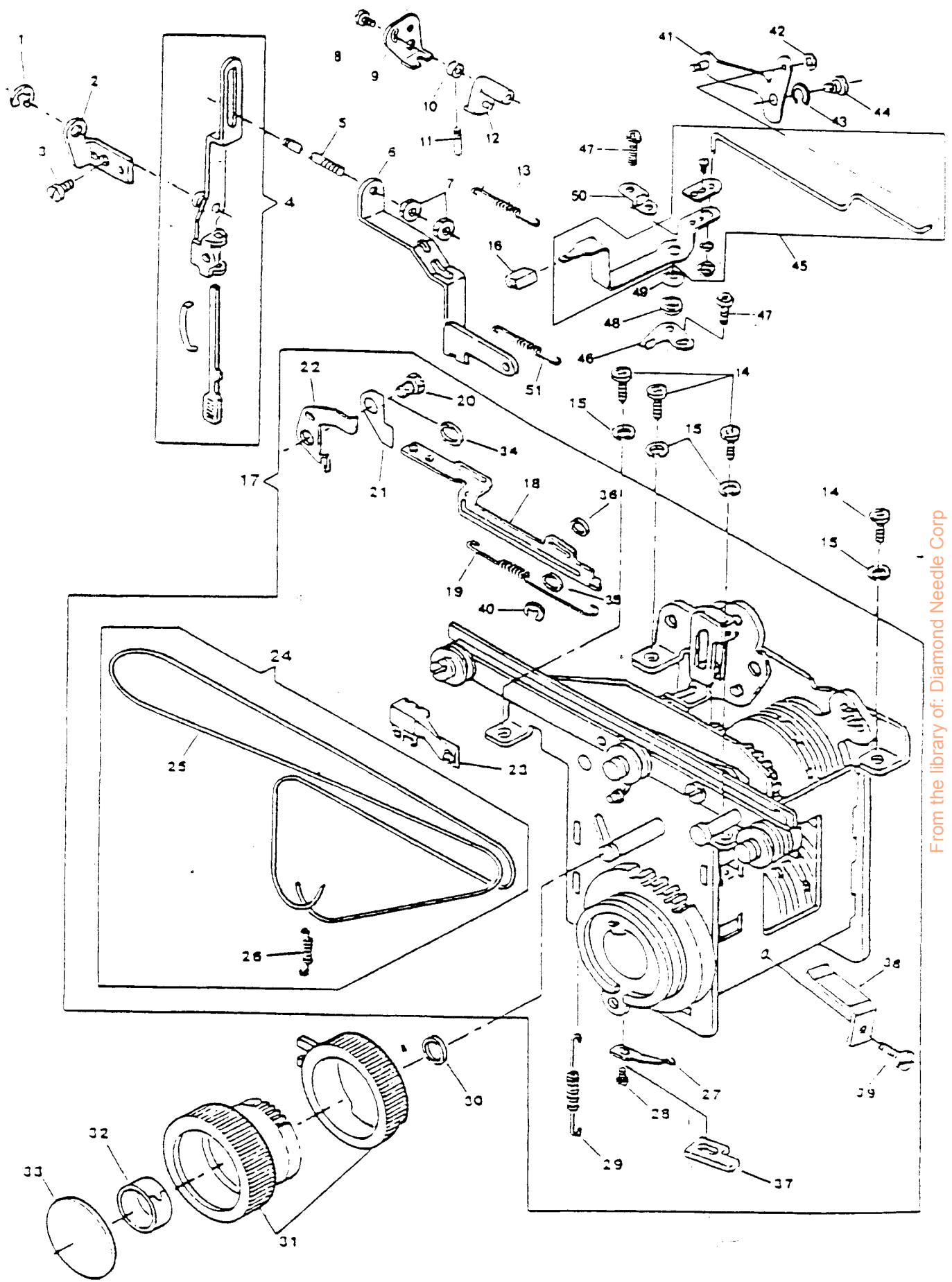

From the library of: Diamond Needle Corp

PATTERN STITCH LENGTH CONTROL AND CAM CONTROLLED FEED (CONT.)

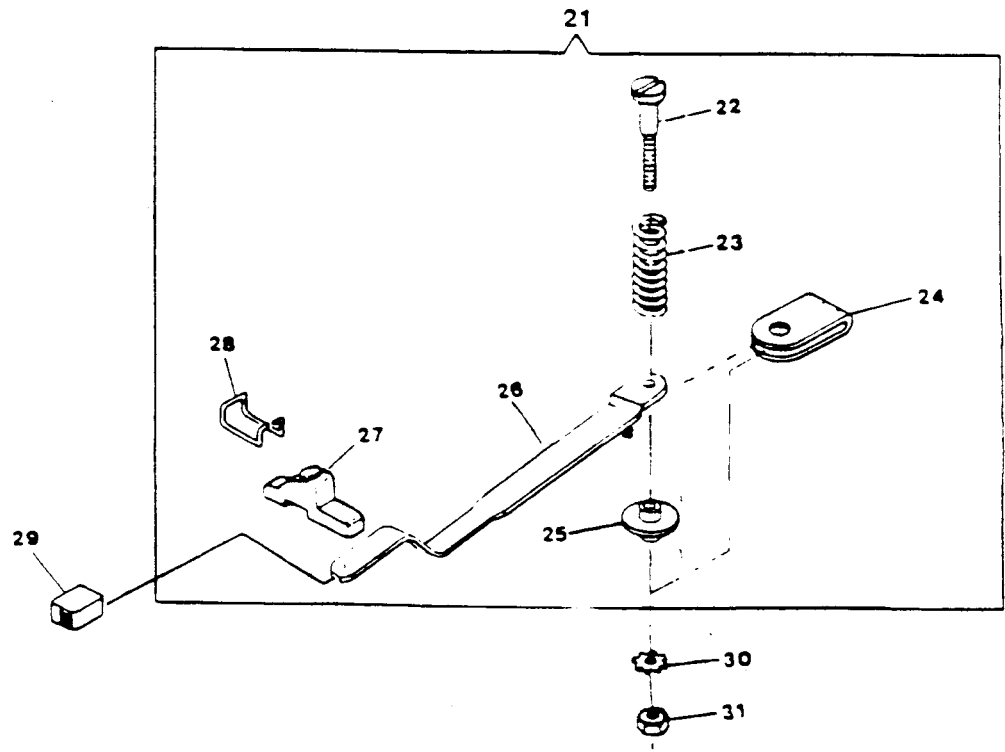
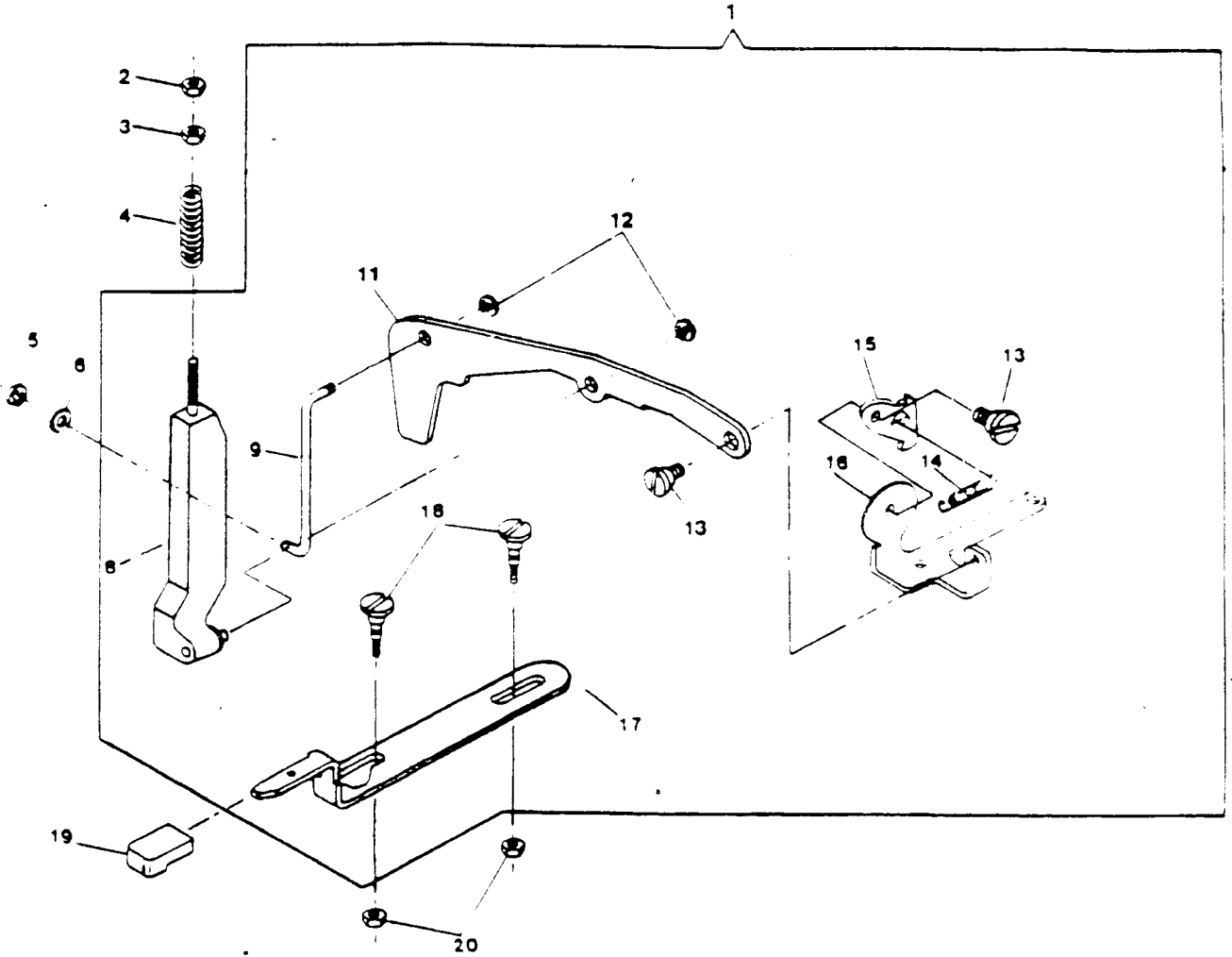

From the library of: Diamond Needle Corp

PATTERN, STITCH LENGTH CONTROL & CAM CONTROLLED FEED (CONT.)

REF. PART NO. NO.	DESCRIPTION	9 4 1 6	9 4 3 0
1	314300-001 FEED REVERSE MECHANISM		
2	514674-451 CAM CONTROLLED FEED CONNECTING ROD LOCKING NUT	X	X
3	312645-451 CAM CONTROLLED FEED DISC FOLLOWER ACTUATOR CONNECTING ROD ADJUSTING NUT	X	X
4	313143 CAM CONTROLLED FEED DISC FOLLOWER ACTUATOR CONNECTING ROD SPRING	X	X
5	312702 FEED LEVER CONNECTING LINK RETAINING RING	X	X
6	313891 CAM CONTROLLED FEED CONNECTING ROD STABILIZING WASHER	X	X
8	314549 CAM CONTROLLED FEED DISC FOLLOWER ACTUATOR CONNECTING ROD	X	X
9	313057 FEED LEVER CONNECTING LINK	X	X
11	314283 STITCH LENGTH CONTROL ARM	X	X
12	312702 CAM CONTROLLED FEED DISC FOLLOWER ACTUATOR CONNECTING ROD RETAINING RING	X	X
13	354958-451 REVERSE FEED LEVER PIVOT SCREW		
14	314282 REVERSE FEED CRANK SPRING	X	X
15	314281 REVERSE FEED CRANK	X	X
16	314279-900 REVERSE FEED LEVER MOUNTING BRACKET	X	X
17	314280 REVERSE FEED CONTROL LEVER	X	X
18	113499-451 REVERSE FEED CONTROL LEVER & LATCH SCREW	X	X
19	312657-460 REVERSE FEED CONTROL LEVER KNOB (PLASTIC)	X	X
20	514674-451 REVERSE FEED CONTROL LEVER GUIDE SCREW NUT	X	X
21	313569 STITCH LENGTH CONTROL LEVER ASSEMBLY	X	X
22	113356-451 STITCH LENGTH CONTROL LEVER PIVOT SCREW	X	X
23	313567 STITCH LENGTH CONTROL LEVER SPRING	X	X
24	313566 STITCH LENGTH CONTROL FRICTION WASHER	X	X
25	313565-451 STITCH LENGTH CONTROL LEVER NUT	X	X
26	312663 STITCH LENGTH CONTROL LEVER	X	X
27	313960 STITCH LENGTH CONTROL LEVER CAM ASSEMBLY	X	X
28	313188 STITCH LENGTH CONTROL LEVER CAM RETAINING CLIP	X	X
29	312664-460 STITCH LENGTH CONTROL LEVER KNOB (PLASTIC)	X	X
30	313172-451 STITCH LENGTH CONTROL LEVER PIVOT LOCK WASHER	X	X
31	313177-451 STITCH LENGTH CONTROL LEVER NUT	X	X

DEMAND RESPONSIVE NEEDLE TENSION SYSTEM

REF. PART NO. NO.	DESCRIPTION	9 9 4 4 1 3 6 0
1	313199 TENSION COVER MOUNTING RETAINER	X X
2	313077-009 THREAD TENSION MODULE	X X
3	314299-451 TENSION REGULATOR LEVER STUD NUT	X X
4	312708 TENSION SPRING	X X
5	312710 TENSION SPRING WASHER	X X
6	314002 TENSION MOUNTING PLATE SUB-ASSEMBLY TAKE-OFF	X X
7	113442-003 TENSION COVER MOUNTING SCREW	X X
8	53641 TENSION COVER RETAINING STUD NUT	X X
9	312703 TENSION DISC	X X
9	313403 TENSION DISC (ALTERNATE TO 312703)	X X
11	312705 TENSION RELEASE PIN	X X
12	314005 PRE-TENSION SPRING	X X
13	312707 TENSION LEVER	X X
13	313904 TENSION LEVER (ALTERNATE)	X X
14	313048 TENSION REGULATING LEVER SLIDE BLOCK	X X
15	312946 TENSION REGULATING LEVER ASSEMBLY	X X
16	317010-002 TENSION COVER ASSEMBLY	X X
17	312664-460 TENSION REGULATING KNOB	X X
18	313047 TENSION COVER RETAINING CLIP	X X
19	314309 TENSION COVER SPACER (UPPER)	X X
20	314685-900 THREAD WEAR PLATE (APOLLO)	X X
21	314687-900 THREAD GUIDE	X X
22	314688 THREAD TAKE-UP WEAR PLATE ASS'Y (APOLLO)	X X
23	314690 THREAD PINCH PLATE	X X
24	314686-900 THREAD GUIDE RIVET	X X
25	317166 PINCH PLATE MOUNTING SCREW WASHER	X X
26	113524-451 MOUNTING SCREW	X X

DEMAND RESPONSIVE NEEDLE TENSION SYSTEM

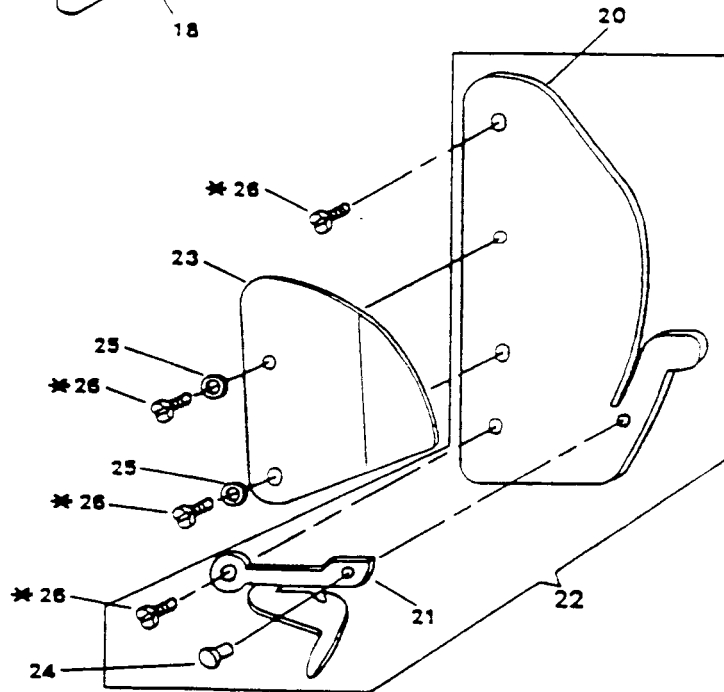
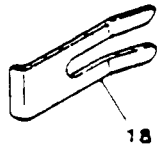
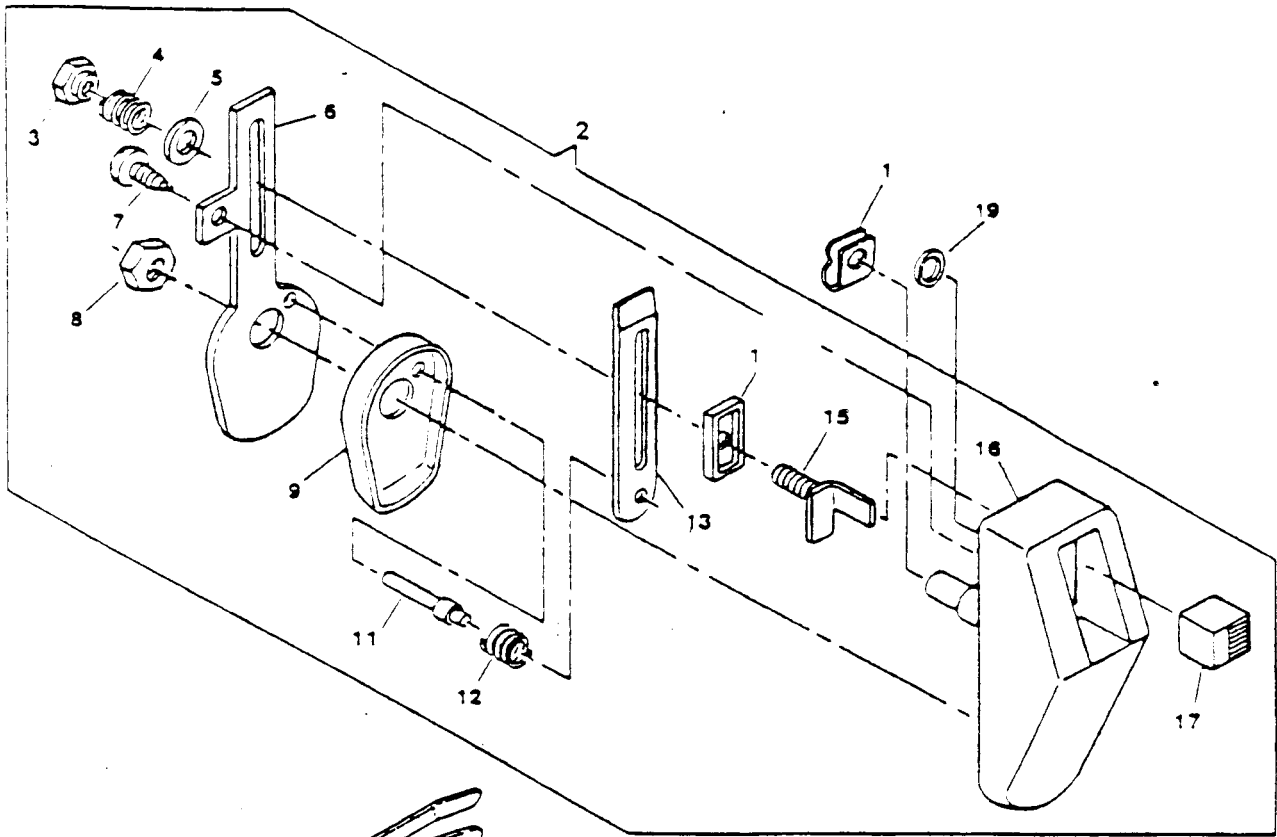

ELECTRICAL EQUIPMENT

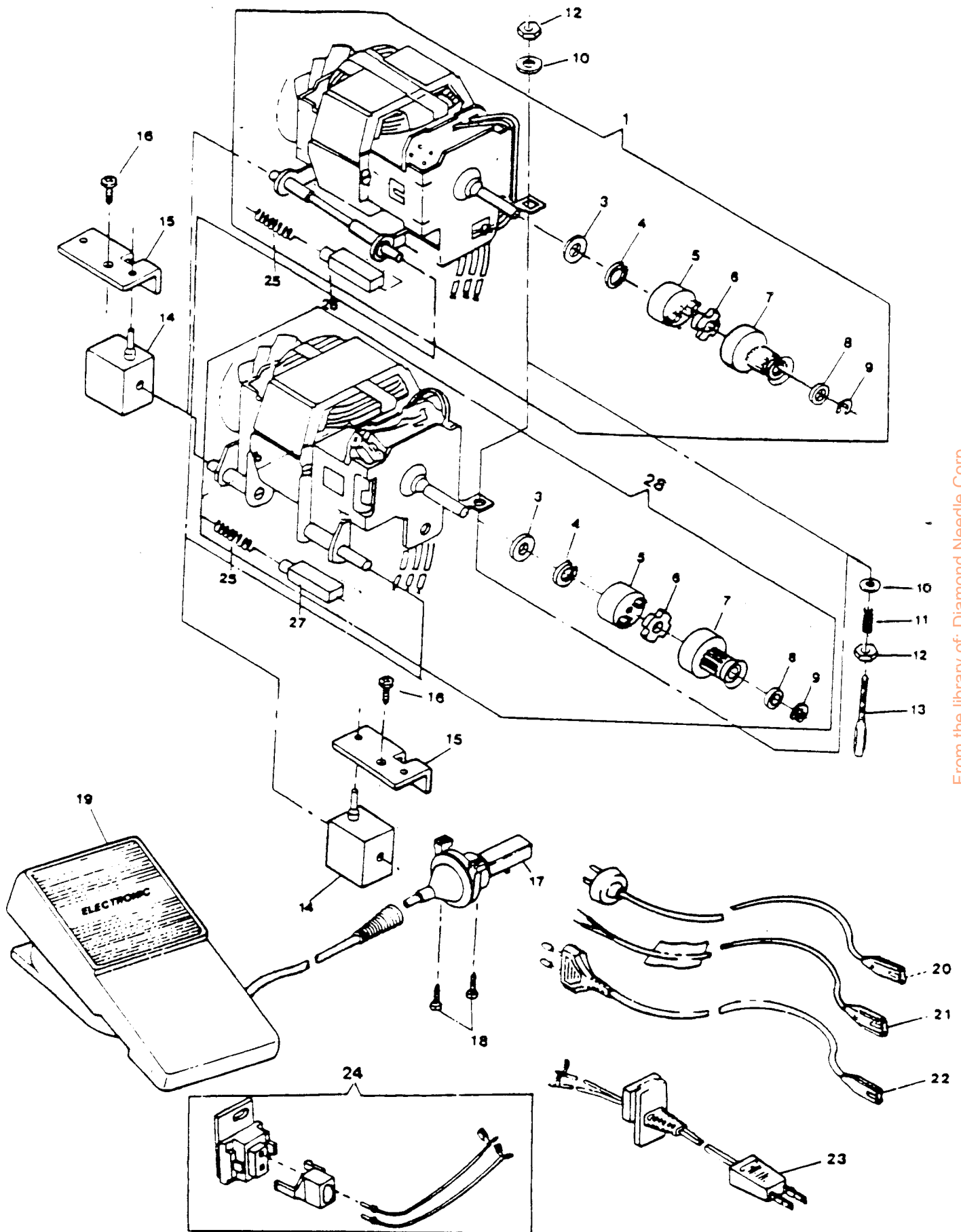

ELECTRICAL EQUIPMENT

REF. PART NO.	DESCRIPTION	9	9
		4	4
		1	3
		6	0
1	988529-009	MOTOR COMP. (CAT. NO. TA4-8) 120 VOLT (NATIONAL MOTOR)	X X
1	988529-010	MOTOR COMP. (CAT. NO. TA4-11) 220/240 VOLT (NATIONAL MOTOR)	X X
3	931744-001	SPACER WASHER (AS REQUIRED)	X X
3	931744-002	SPACER WASHER (AS REQUIRED)	X X
3	931744-003	SPACER WASHER (AS REQUIRED)	X X
3	931744-103	SPACER WASHER (AS REQUIRED)	X X
4	603908-001	RETAINING RING	X X
5	988738-002	MOTOR PULLEY ISOLATOR HUB	X X
6	988795-001	MOTOR PULLEY TORQUE CUSHION	X X
7	979124-001	PULLEY WITH BELT RETAINER	X X
8	988717-001	WASHER	X X
9	619279-902	MOTOR PULLEY ISOLATOR HUB RETAINING RING	X X
10	37969	MOTOR ADJUSTING STUD NUT WASHER	X X
11	314058	MOTOR BELT TENSION SPRING	X X
12	53646	MOTOR ADJUSTING STUD NUT	X X
13	988653-001	MOTOR ADJUSTING STUD	X X
14	979329-001	RESILIENT MOUNT	X X
15	988651-001	CLIP	X X
16	113470-004	MOTOR MOUNTING SCREW	X X
17	988549-005	PNEUMATIC TRANSDUCER	X X
18	113444-003	PNEUMATIC TRANSDUCER MOUNTING SCREW	X X
19	988667-001	PNEUMATIC CONTROLLER ASSEMBLY <i>cheaper use of 795830</i>	X X
20	988638-004	APPLIANCE COUPLER FOR AUSTRALIA (BICENTENNIAL)	X X
21	988638-003	APPLIANCE COUPLER (240 VOLT) FOR U.K.	X X
22	988638-001	APPLIANCE COUPLER (220 VOLT) FOR EUROPE	X X
23	988557-001	CORD W/STRAIN RELIEF AND PLUG (120 VOLT) FOR U.S./CANADA	X X
24	988657-003	CORD WITH RECEPTACLE (EUROPE/U.K./AUSTRALIA/JAPAN)	X X
25	619436-001	BRUSH SPRING (2)	X X
26	619435-013	MOTOR BRUSH (2) (FOR NATIONAL MOTOR)	X X
27	619435-015	MOTOR BRUSH (2) (FOR ITU MOTOR)	X X
28	988529-009	MOTOR COMP. (CAT. NO. TA4-8) 120 VOLT (ITU MOTOR)	X X
28	988529-010	MOTOR COMP. (CAT. NO. TA4-11) 220/240 VOLT (ITU MOTOR)	X X

ELECTRICAL EQUIPMENT (CONT.)

REF. NO.	PART NO.	DESCRIPTION	9	9
			4	4
			1	3
			6	0
1	314596-001	LINT AND HEAT SHIELD ASSEMBLY (220/240V)	X	X
2	979203-002	LIGHT ASSEMBLY (EUROPE) (220V)	X	X
2	979203-003	LIGHT ASSEMBLY (AUSTRALIA) (240V) (BICENTENNIAL)	X	X
3	540899	TY-WRAP SELF-LOCKING (ALT: 505600-001)	X	X
4	979203-001	LAMP SOCKET (120V) (US/CANADA)	X	X
5	314596-002	LINT AND HEAT SHIELD ASSEMBLY (100V)	X	
5	314596-003	LINT AND HEAT SHIELD ASSEMBLY (120V)	X	X
6	446138	HEAT SHIELD MOUNTING SCREW WASHER	X	X
7	544211-002	HEAT SHIELD MOUNTING SCREW	X	X
8	194120-021	LIGHT BULB (240 VOLT) (ALT: 542656-004) (BICENTENNIAL)	X	X
8	194120-020	LIGHT BULB (220 VOLT) (ALT: 542656-003)	X	X
8	194120-019	LIGHT BULB (120 VOLT) (ALT: 542656-005)	X	X
9	113445-003	THREAD TAKE-UP COVER AND LINT/HEAT SHIELD SCREW	X	X
10	988547-002	WASHER	X	X
11	113444-001	SCREW (P. C. BOARD MOUNTING)	X	X
12	988548-001	SWITCH OPERATOR (120 VOLT)	X	X
12	988548-002	SWITCH OPERATOR (220/240 VOLTS)	X	X
13	988547-001	WASHER	X	X
14	979123-004	SPEED CONTROL P. C. BOARD ASSEMBLY 120 VOLT (FULL WAVE)	X	X
14	979120-005	SPEED CONTROL P. C. BOARD ASSEMBLY 220/240 VOLTS (FULL WAVE)	X	X
14	979161-003	SPEED CONTROL P. C. BOARD ASSEMBLY 100 VOLT (FULL WAVE)	X	X
14	979192-005	SPEED CONTROL P. C. BOARD ASSEMBLY 220/240 VOLTS (FULL WAVE)	X	X
15	113455-001	SCREW (LIGHT HARNESS)	X	X
16	604690-001	SELF-LOCKING NYLON CABLE TIE (LIGHT HARNESS)	X	X

ELECTRICAL EQUIPMENT (CONT.)

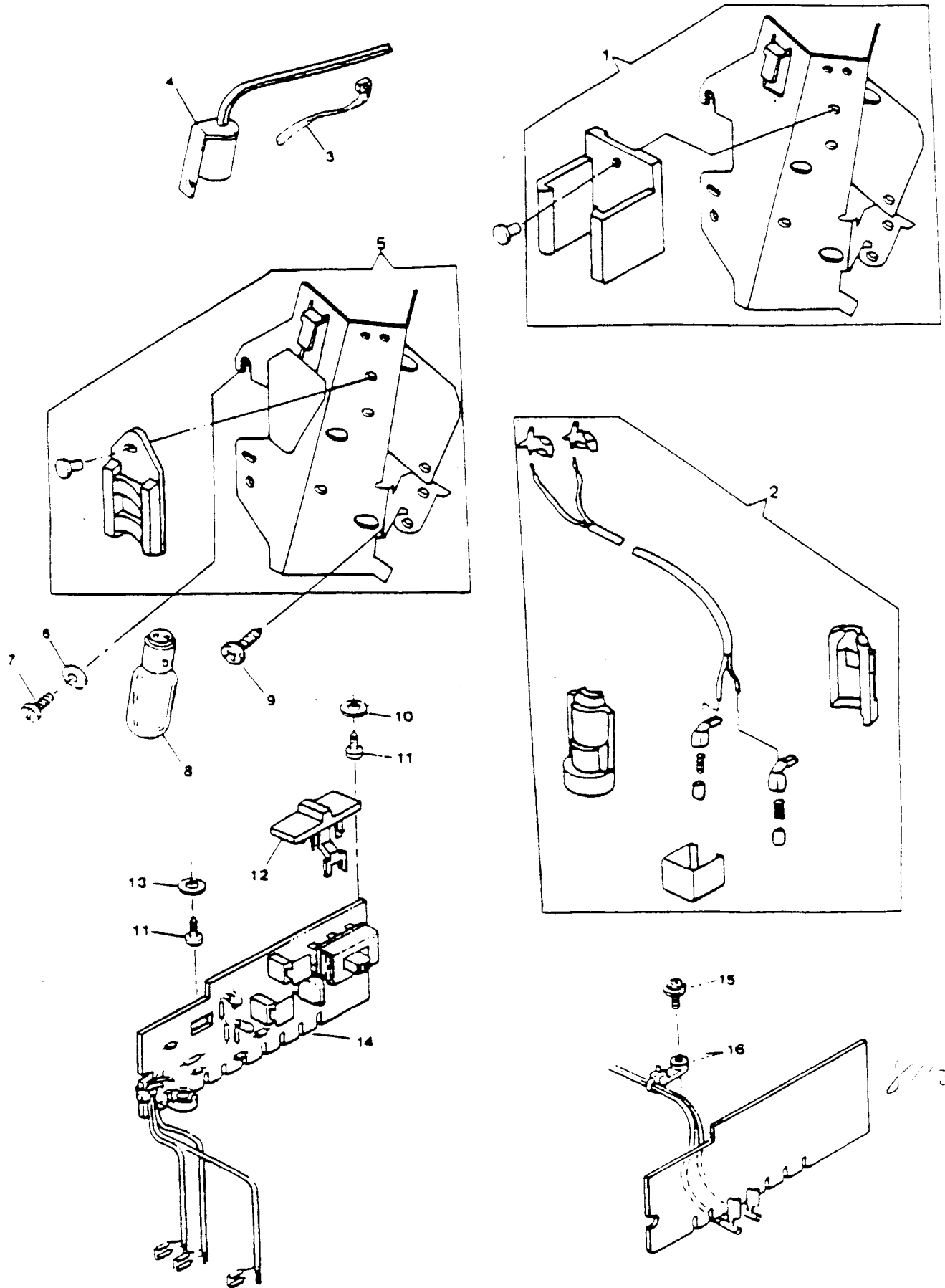

From the library of: Diamond Needle Corp

811393421